

DL-50 Series

Dome-loaded Pressure Regulator

The DL-50 is a compact and robust design which employs a unique “Dual Piston” set up that enables the user to control pressure up to 6000 psig(414 bar) with as little as 100 psig(7 bar) of dome pressure. All of this is accomplished within the smallest envelope the industry has to offer.

The regulator portion of this unit was patterned after the time tested PR-50 Series, which is widely recognized as a benchmark of performance and quality. Offering the utmost in economy and safety, this unit is constructed from 316L stainless steel. A carefully engineered diaphragm/piston sensor unit offers good sensitivity and repeatability.

Completing this design is the addition of an anodized aluminum (316 stainless steel optional) dome unit. The inlet ring to the dome is freely rotating and captured by a high tensile snap ring. This feature allows easy positioning and alignment of the dome gas line within a customer’s system while maintaining excellent leak integrity.



pressure regulators

Typical Applications

- Pilot plant
- Off-shore oil and gas rigs
- Pneumatic test benches
- Component testing
- R & D systems
- High pressure booster systems

Features & Benefits

- Gas or liquid service
- Better than 25 Ra finish in diaphragm cavity
- 20 micron inlet filter
- Bubble-tight shutoff
- Diaphragm type sensing
- Remote dome-loading

Technical Data

CONSTRUCTION	316L stainless steel construction (Brass and MONEL® optional)
DOMES RATIOS	11.5 : 1, 20 : 1
INLET/OUTLET PORTS	¼" FNPT (standard)
OUTLET PRESSURE	up to 2000 psig (138 bar)
Cv COEFFICIENTS	0.025, 0.06, 0.2

DL-50 Series

To Order, contact your local Distributor Link below:
www.goreg.com/distributor/index.htm

Verify that your chosen part number is valid using the GO Wizards at
www.goreg.com/products/matrix/index.htm

How to Order

Standard items in bold.

DL50 - 1 A 1 1 C 3 1 1 6 1 A

BODY MATERIAL

- 1** 316L stainless steel
- 2 Brass
- 4 MONEL®

PORT CONFIGURATIONS

- A** Standard
- For more port configurations, see page 9.

PROCESS PORT TYPES

(GAUGE PORT TYPE, IF SPECIFIED)

- 1** 1/4" FNPT (1/4" FNPT gauge ports)
- 4 3/8" FNPT (1/4" FNPT gauge ports)

SURFACE FINISH OF DIAPHRAGM CAVITY

- 1** < 25 Ra
- 5 < 25 Ra with 10-32 mounting holes

SEAT MATERIAL

- A** Tefzel®
- H** PCTFE (formerly Kel-F® 81)
- Q** PEEK™

NOTE: Contact the factory for any additional requirements.

OPTIONS

- A** EB33 (oxygen cleaning)
- B** EB5 cleaning
- D** Helium leak test
- E** Pressure test certificate
- F** Certificate of Conformity
- G** CMTR

DOMESTYLE

- 1** Standard, aluminum
- 2** Captured vent, aluminum
- 3** Stainless steel
- 4** Captured vent, stainless steel

DIAPHRAGM FACING/BACKING MATERIAL

	Facing	Backing	O-rings	Actuator
1	St. steel	Nylon	Viton®	St. steel
2	—	Nylon	PTFE	St. steel
3	Polyimide	Nylon	Viton®	St. steel
4	St. steel	Nylon	PTFE	St. steel
5	—	Nylon	PTFE	MONEL®
6	Polyimide	Nylon	PTFE	St. steel
7	INCONEL®	Nylon	Viton®	MONEL®
8	INCONEL®	Nylon	PTFE	MONEL®
B	—	Nylon	Viton®	MONEL®
H	—	Nylon	Viton®	St. steel
Q	St. steel	PTFE	PTFE	St. steel
V	INCONEL®	PTFE	PTFE	MONEL®

DIAPHRAGM TYPE

- 1** Non-self-relieving
- 3** Self-relieving

DOMERATIO

- 1** 11.5 : 1
- 2** 20 : 1

FLOW COEFFICIENT (CV)

- 3** **0.06**
- 5** 0.2
- C** 0.025

Maximum Temperature & Operating Inlet Pressures

Nylon Diaphragm Backing

SEAT MATERIAL	MAXIMUM TEMPERATURE	@	MAXIMUM OPERATING INLET PRESSURE
Tefzel®	150° F (66° C)	@	3600 psig (248 bar)
PCTFE (formerly Kel-F® 81)	175° F (80° C)	@	6000 psig (414 bar)
PEEK™	175° F (80° C)	@	6000 psig (414 bar)

PTFE Diaphragm Backing

SEAT MATERIAL	MAXIMUM TEMPERATURE	@	MAXIMUM OPERATING INLET PRESSURE
Tefzel®	150° F (66° C)	@	3600 psig (248 bar)
PCTFE (formerly Kel-F® 81)	175° F (80° C)	@	6000 psig (414 bar)
PEEK™	350° F (177° C)	@	6000 psig (414 bar)

MONEL® is a registered trademark of Special Metals Corporation.
 Tefzel® is a registered trademark of the DuPont Company.
 Kel-F® is a registered trademark of 3M Company.
 PEEK™ is a trademark of Victrex PLC.
 Viton® is a registered trademark of DuPont Dow Elastomers.

Outline and Mounting Dimensions

Weight = 5.1 lbs (2.31kg)

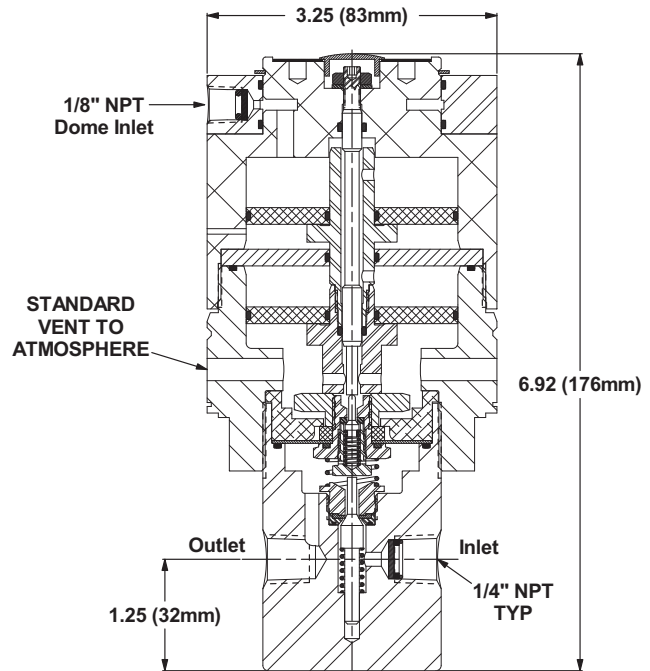

11.5:1 RATIO, S/R, 0.2 Cv