

## INTELLIS NETWORK CONTROL MONITORS

NON-INCENDIVE, INTRINSICALLY SAFE AND EXPLOSIONPROOF - NEC

Intellis is a family of fully-integrated control monitors that provide cost-effective valve automation and intelligent networking via all the major network protocols



### FEATURES

- Dedicated network modules (PACs) for all major protocols.
- Simple in-field conversion of network protocols.
- Multiple housing options (resin, aluminum, stainless steel).
- Models approved for all hazardous area applications.
- Control & monitoring for rotary and linear valves.
- Non-contact position monitoring by Hall effect sensors.
- Integrated pneumatic actuation control via pre-wired Falcon solenoid valves.
- On-line predictive and maintenance-related diagnostics.
- Eliminates wiring cost of conventionally-hardwired I/O systems.
- Reduces design engineering man-hours
- Range of drive shaft options.
- Visual indication Beacon available in a choice of styles and colors.

### TECHNICAL DATA

#### Agency approvals

Area Classification (NEC 500)  
Non-incendive

Intrinsically Safe

Explosionproof

Enclosure standards (ANSI/NEMA 250)  
All Enclosures

#### Network protocols supported

Intellis 7200  
Intellis 7300  
Intellis 7400  
Intellis 7500  
Intellis 7600  
Intellis 7700

#### Enclosures

Class I, Division 2, Groups A, B, C & D  
Class II & III, Division 2, Groups F & G  
Class I, Division 1, Groups A, B, C & D  
Class I, None 0, IIC  
Class I, Division 2, Groups A, B, C & D  
Class II & III, Division 2  
Class I, Division 1, Groups C & D  
Class II & III, Division 2, Groups E, F & G

Type 4, 4X

PROFIBUS DP  
FOUNDATION Fieldbus™  
ModBus® Direct  
ModBus®  
DeviceNet™  
AS-interface® Ver. 2.1

Engineered resin  
Aluminum

### GENERAL APPLICATION

Intellis network control monitors use embedded control systems to automate valves and link field I/O to the host PLC or DCS. They incorporate all the features of standard Westlock control monitors with the addition of a network I/O module.

# INTELLIS NETWORK CONTROL MONITORS

## NON-INCENDIVE, INTRINSICALLY SAFE AND EXPLOSIONPROOF - NEC

### NETWORK SYSTEMS FOR VALVE AUTOMATION

Intellis is a family of field network control monitors which use embedded control systems to automate valves and link field I/O to the host PLC or DCS. They incorporate all the features of our standard control monitors with the addition of a network I/O module.

Each network monitor houses two discrete Hall effect sensors for valve position monitoring, a low power solenoid valve for actuation control and a network interface module for communication via the chosen network protocol. Monitors are available for linear and rotary applications in all area classifications.

#### THE NETWORK MODULE

Each Intellis model contains a dedicated network module (Pac) that is integrated within its enclosure. A different Pac is factory-integrated depending upon the network protocol selected. The Pacs' modular design enables the simple conversion of units from one network protocol to another (with the sole exception of FOUNDATION Fieldbus™) in the field by authorized personnel, should the need arise.

Integrated network modules have protective diodes and optical isolation as standard. They are housed in general purpose, Division 2 Non-incendive or Explosionproof enclosures with a 16 point terminal block for simple wiring.

#### Peripheral interface devices

- Cables
- Power supplies
- Gateways
- Repeaters
- Extenders
- Configuration tools
- Software/diagnostics
- Junction boxes

#### STANDARD NETWORK PROTOCOLS

The development of standard network protocols has made it possible to integrate process control components into a network effectively. ModBus®, DeviceNet™, AS-interface®, PROFIBUS and FOUNDATION Fieldbus™ are now the standards for interfacing discrete devices. They are proven to be extremely reliable, simple to understand and consistently cost-effective. They integrate simply with all major PLCs and DCS systems via off-the-shelf gateway interfaces.

#### ACCESSORIES

We are committed to making your network design, procurement and installation experience easier. To complement our wide array of network valve monitoring and control products, we offer a variety of accessories to meet your network connectivity and power requirements. From power supplies and cables to gateways and junctions, we've got what you need to get the job done efficiently.

#### SERVICES

We offer expert services for the design and installation of ASi®, DeviceNet™, ModBus®, PROFIBUS and FOUNDATION Fieldbus™ networks. This includes the specification of all equipment from the PLC or DCS down.

#### Application support

- Engineering design
- Integration
- Start-up support
- Training
- Turnkey installations



Network module



Gateway interface



Active network tee (ANT)

Junction box



Interconnects

# INTELLIS NETWORK CONTROL MONITORS

## NON-INCENDIVE, INTRINSICALLY SAFE AND EXPLOSIONPROOF - NEC

### FIELD NETWORK

A field communications network comprises a specific number of network monitors interconnected by a common communications protocol. Network monitors may be placed on the field network in any physical order. Each monitor is assigned a unique address and accepts input/output signals from valve position sensors, solenoids and external devices.

Communication with a PLC, DCS or host computer is accomplished by a compatible gateway interface or scanner card.

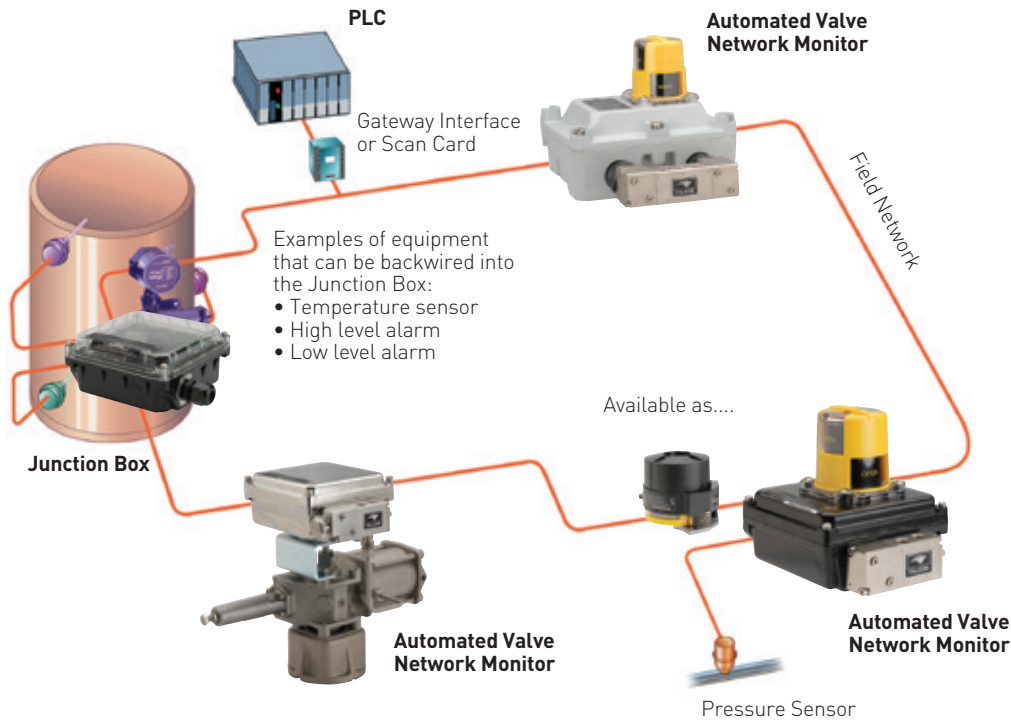

#### **AUTOMATED VALVE NETWORK MONITOR**

The network monitor for automated valves couples directly onto the pneumatic or electric actuator. Each unit can accept input/output signals from position sensors and solenoid valves while simultaneously performing on-line diagnostics. In addition, each network monitor will interact with a comprehensive range of external field devices for control or alarm purposes.

#### **EXTERNAL DEVICE NETWORK MONITOR**

Network monitors are available for control or monitoring of non-valve related devices including sensors, alarms, actuators, indicating lights, etc. Depending on the protocol, each stand-alone network monitor is capable of accepting up to six external devices within the primary control network.

# INTELLIS NETWORK CONTROL MONITORS

## INTELLIS 7200 PROFIBUS



### INTELLIS 7200 PROFIBUS

PROFIBUS (Process Field Bus) has been a standard for field bus communication in automation technology since it was first developed in 1989.

#### PROFIBUS

Physical media	Twisted pair for communications, two wires for power
Maximum distance	3960 ft. (1200 m) trunk
Maximum network monitors per system	32/segment; 126/system using repeaters
Maximum I/O points per system	1125/system
Current consumption per network monitor	120 mA
Interface capability	All PLCs and DCS supporting the PROFIBUS protocol
Communications method	Peer to peer and cyclic Master/slave
Error checking	CRC check
Network topology	Linear, preferred, drops allowed at Baud rates below 500 kbps
Transmission speed	9.6, 19.2, 93.75, 187.5, 500, 1500, 12000 kbps
Redundancy	No
Valves specific diagnostics	Yes

#### NOTES

1. Please contact your sales office for guidance on selecting the best possible combination for your control and monitoring requirements.
2. See Hazardous area classification technical bulletin for further information on global standards.

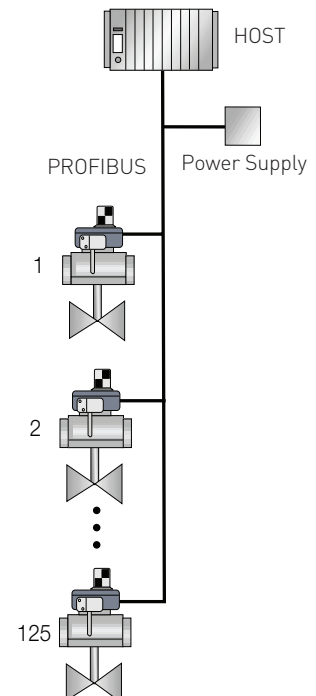

# INTELLIS NETWORK CONTROL MONITORS

## INTELLIS 7300 FOUNDATION FIELDBUS™



### INTELLIS 7300 FOUNDATION FIELDBUS™

Foundation Fieldbus is an all-digital, serial two-way communications system that is an open architecture, developed and administered by the Fieldbus Foundation.



#### FOUNDATION FIELDBUS™

Physical media	Two wire cable (communications and power)
Maximum distance	6720 ft. (1900 m) including spurs
Maximum network monitors per system	6/segment if bus powered & IS; 12/segment if bus powered & non-IS; 32/seg. if neither bus powered nor IS
Maximum I/O points per system	192/system
Current consumption per network monitor	18-24 mA IS
Interface capability	All PLCs and DCS supporting the FF protocol
Communications method	Peer to peer
Error checking	CRC check
Network topology	Daisy chain, trunk/drop (spurs), branching drop (spurs), point to point
Transmission speed	31.25 kbps
Redundancy	Yes
Valves specific diagnostics	Yes

#### NOTES

1. Please contact your sales office for guidance on selecting the best possible combination for your control and monitoring requirements.
2. See Hazardous area classification technical bulletin for further information on global standards.

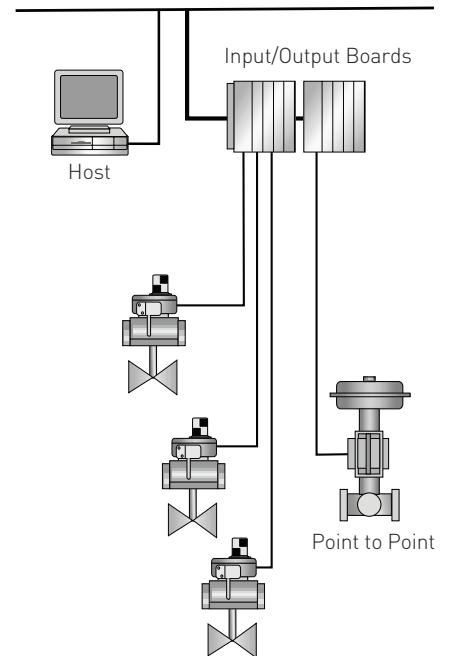

# INTELLIS NETWORK CONTROL MONITORS

## INTELLIS 7400 MODBUS® DIRECT



### INTELLIS 7400 MODBUS® DIRECT

ModBus® Direct devices can be connected to any PLC or DCS with a ModBus® port.

#### MODBUS® DIRECT

Physical media	Twisted pair for communications, two wires for power
Maximum distance	3000 ft. (909 m)
Maximum network monitors per system	127 per one ModBus master
Maximum I/O points per system	256/network plus optional 4/20mA analog I/O 256/system
Current consumption per network monitor	27 mA + 20-25 mA/coil
Interface capability	All PLCs and DCS with ModBus® port
Communications method	Master/slave with cyclic polling
Error checking	CRC check
Network topology	Zero drop
Transmission speed	9.6 kbps, 19.2 kbps
Redundancy	No
Valves specific diagnostics	Yes

#### NOTES

1. Please contact your sales office for guidance on selecting the best possible combination for your control and monitoring requirements.
2. See Hazardous area classification technical bulletin for further information on global standards.

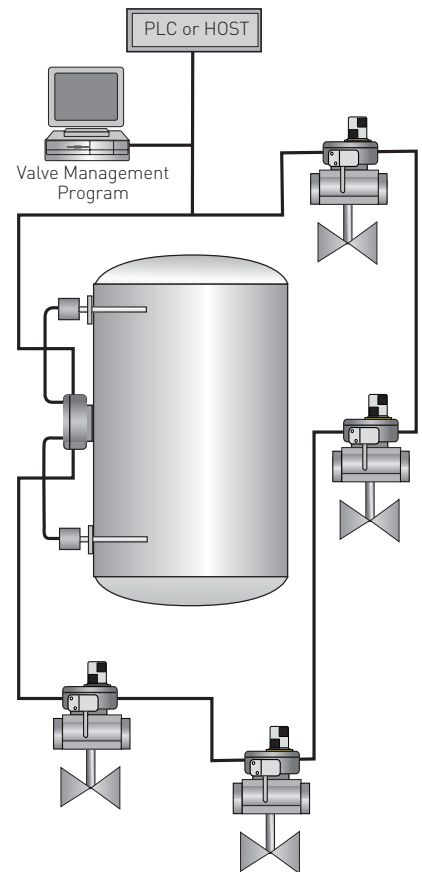

# INTELLIS NETWORK CONTROL MONITORS

## INTELLIS 7500 MODBUS®



### INTELLIS 7500 MODBUS®

The ModBus® protocol operates over a serial interface and is supported by almost every PLC, DCS and operator interface (OI) company.

#### MODBUS®

Physical media	Twisted pair for communications, two wires for power
Maximum distance	3000 ft. (909 m)
Maximum network monitors per system	100/network; 10 networks/system
Maximum I/O points per system	800/network; 8000/system
Current consumption per network monitor	27 mA + 20-25 mA/coil
Interface capability	All PLCs and DCS with ModBus® port
Communications method	Master/slave with cyclic polling
Error checking	CRC check
Network topology	Closed loop bus
Transmission speed	9.6 kbps
Redundancy	Yes
Valves specific diagnostics	Yes

#### NOTES

1. Please contact your sales office for guidance on selecting the best possible combination for your control and monitoring requirements.
2. See Hazardous area classification technical bulletin for further information on global standards.

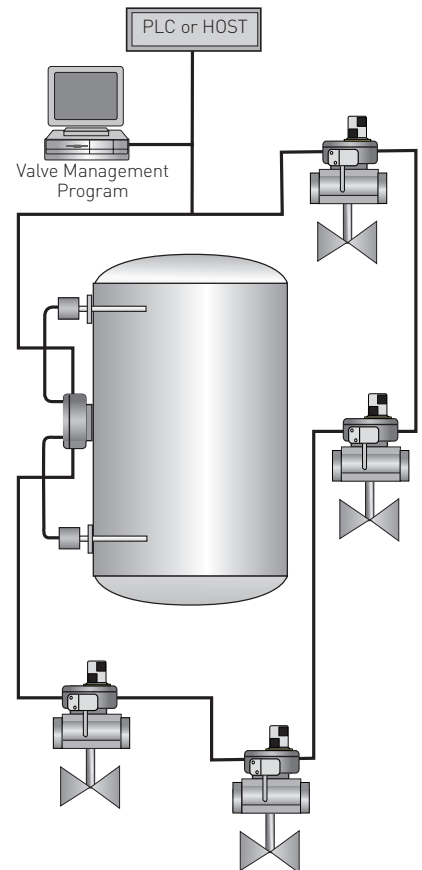

# INTELLIS NETWORK CONTROL MONITORS

## INTELLIS 7600 DEVICENET™

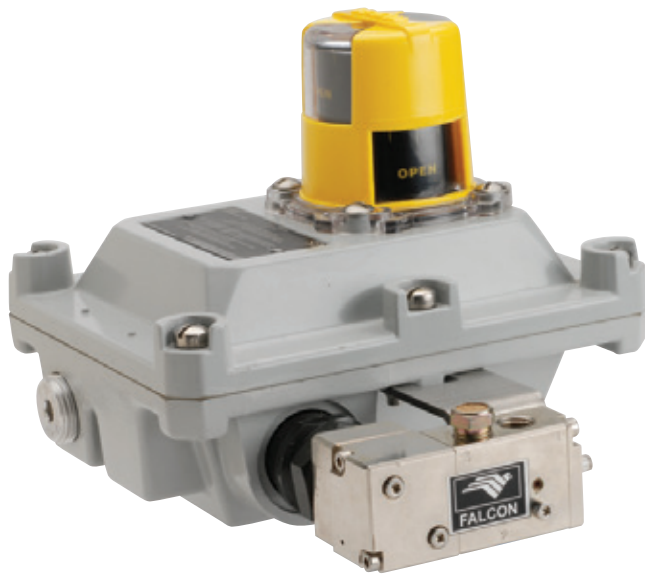

### INTELLIS 7600 DEVICENET™

DeviceNet™ is an open device network standard based upon proven Controller Area Network (CAN) technology.

#### DEVICENET™

Physical media	Twisted pair for communications, two wires for power
Maximum distance	1600 ft.(485 m) trunk + 512 ft. (155 m) drop
Maximum network monitors per system	63/network;
Maximum I/O points per system	378/network plus optional 4/20mA analog I/O 756/system
Current consumption per network monitor	45 mA + 20-25 mA/coil
Interface capability	All PLCs and DCS with DeviceNet™ Interface
Communications method	Master/slave multimaster, peer-to-peer
Error checking	CRC check
Network topology	Zero drop, trunk/drop, daisy chain, branch
Transmission speed	125 kbps, 250 kbps, 500 kbps
Redundancy	No
Valves specific diagnostics	Yes

#### NOTES

1. Please contact your sales office for guidance on selecting the best possible combination for your control and monitoring requirements.
2. See Hazardous area classification technical bulletin for further information on global standards.

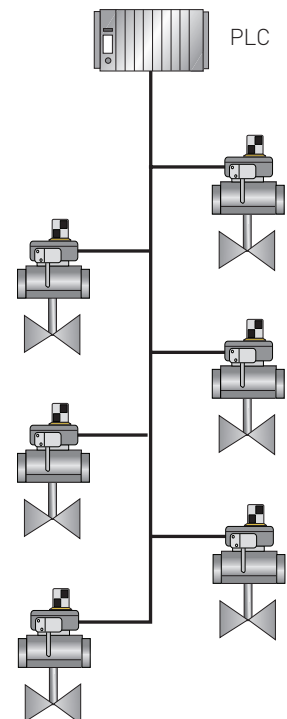



# INTELLIS NETWORK CONTROL MONITORS

## INTELLIS 7700 AS-INTERFACE® VER. 3.0

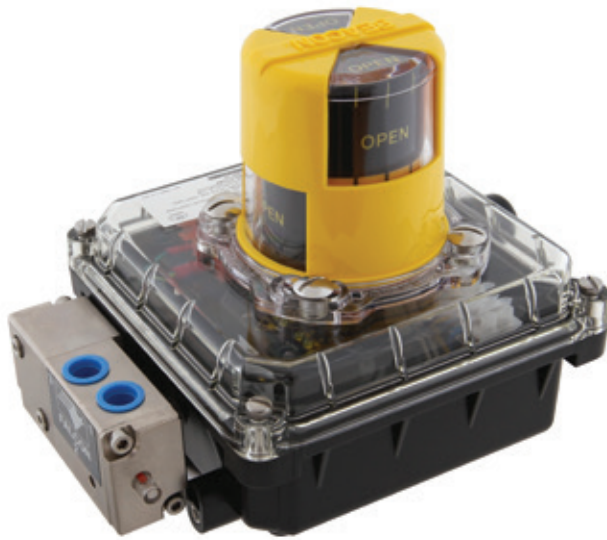

### INTELLIS 7700 AS-INTERFACE® VER. 3.0

The AS-Interface® protocol was developed by a consortium of major European companies. Designed specifically for use in low level automated systems, AS-i can communicate via a gateway to most higher-level bus systems such as DeviceNet™, Modbus® and PROFIBUS.



#### AS-INTERFACE® VER. 3.0

Physical media	Two wire cable (communications and power)
Maximum distance	300 ft. (90.9m) 900 ft. (273 m) with repeater
Maximum network monitors per system	62/network with 2.1 Master, 1 network/system
Maximum I/O points per system	434/network, 434/system
Current consumption per network monitor	{2 in/2 out} 11 mA (power) - 59 mA (1 in/1 out)
Interface capability	All PLC's and DCS with ModBus®, DeviceNet™, PROFIBUS port
Communications method	Master/slave with cyclic polling
Error checking	Control sum, parity
Network topology	Trunk/drop, zero drop
Transmission speed	167 kbps
Redundancy	No
Valves specific diagnostics	No

#### NOTES

1. Please contact your sales office for guidance on selecting the best possible combination for your control and monitoring requirements.
2. See Hazardous area classification technical bulletin for further information on global standards.

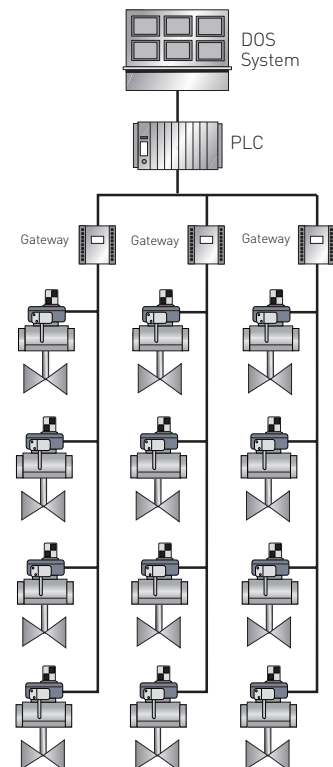

# INTELLIS NETWORK CONTROL MONITORS

## NON-INCENDIVE ALUMINUM ENCLOSURE DIMENSIONS

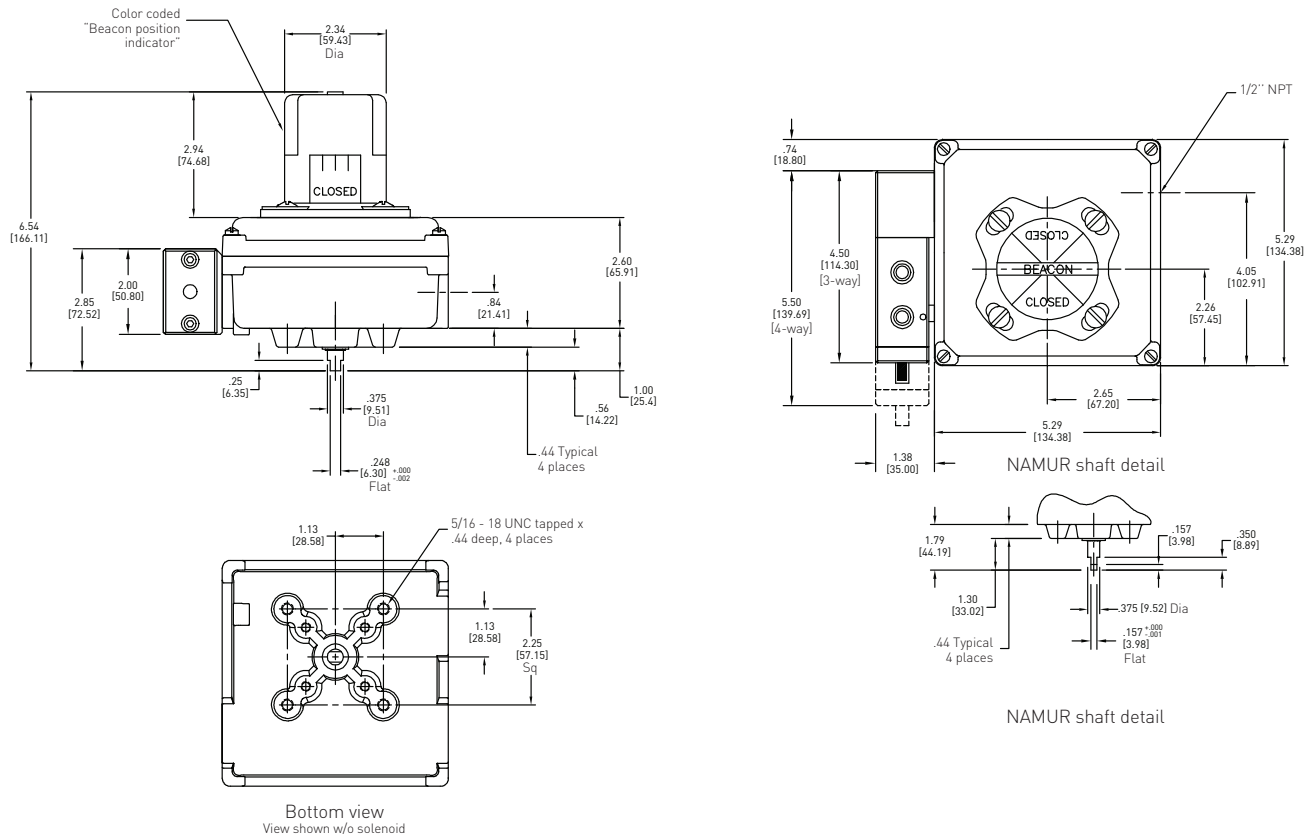

Dimensions in inches, metric dimension (mm) in parentheses

### TECHNICAL SPECIFICATIONS

#### Materials of construction

Enclosure	Aluminum with powder coat finish
Shaft and hardware	Stainless steel
Beacon visual indicator	Co-polyester
Bushing	Oil impregnated bronze

#### Drive shaft

Westlock standard	Double-D with 1/4" A/F
NAMUR standard	NAMUR standard VDI/VDE 3845

### SOLENOID VALVES

The Falcon range of solenoid valves allows you to choose the material, voltage, number of ports, number of coils and  $C_v$  to best suit your application. See the Falcon data sheet for more information.

### NOTES

- Intellis control monitors are available with a choice of conduit entries. Please see the selection guide for standard entries
- Please consult your sales office for any other requirements

# INTELLIS NETWORK CONTROL MONITORS

## NON-INCENDIVE ENGINEERED RESIN ENCLOSURE (SINGLE COIL) DIMENSIONS

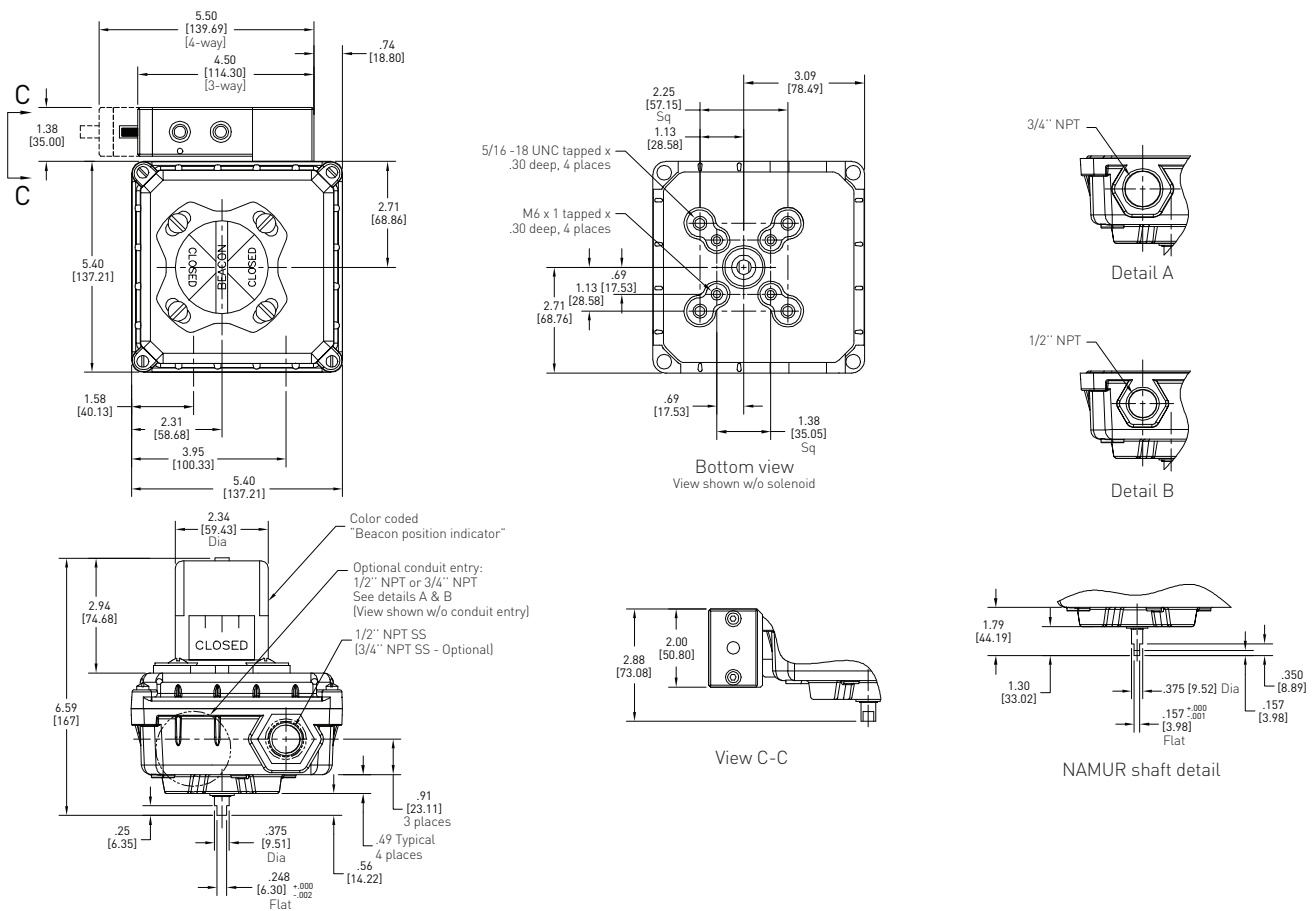

Dimensions in inches, metric dimension (mm) in parentheses

### TECHNICAL SPECIFICATIONS

#### Materials of construction

Enclosure	Engineered polyamide resin
Shaft and hardware	Stainless steel
Beacon visual indicator	Co-polyester
Bushing	Nylon
<b>Drive shaft</b>	
Westlock standard	Double-D with 1/4" A/F
NAMUR standard	NAMUR standard VDI/VDE 3845

#### NOTES

- Intellis control monitors are available with a choice of conduit entries. Please see the selection guide for standard entries
- Please consult your sales office for any other requirements

### SOLENOID VALVES

The Falcon range of solenoid valves allows you to choose the material, voltage, number of ports, number of coils and  $C_v$  to best suit your application. See the Falcon data sheet for more information.

# INTELLIS NETWORK CONTROL MONITORS

## NON-INCENDIVE ENGINEERED RESIN ENCLOSURE (DUAL COIL) DIMENSIONS

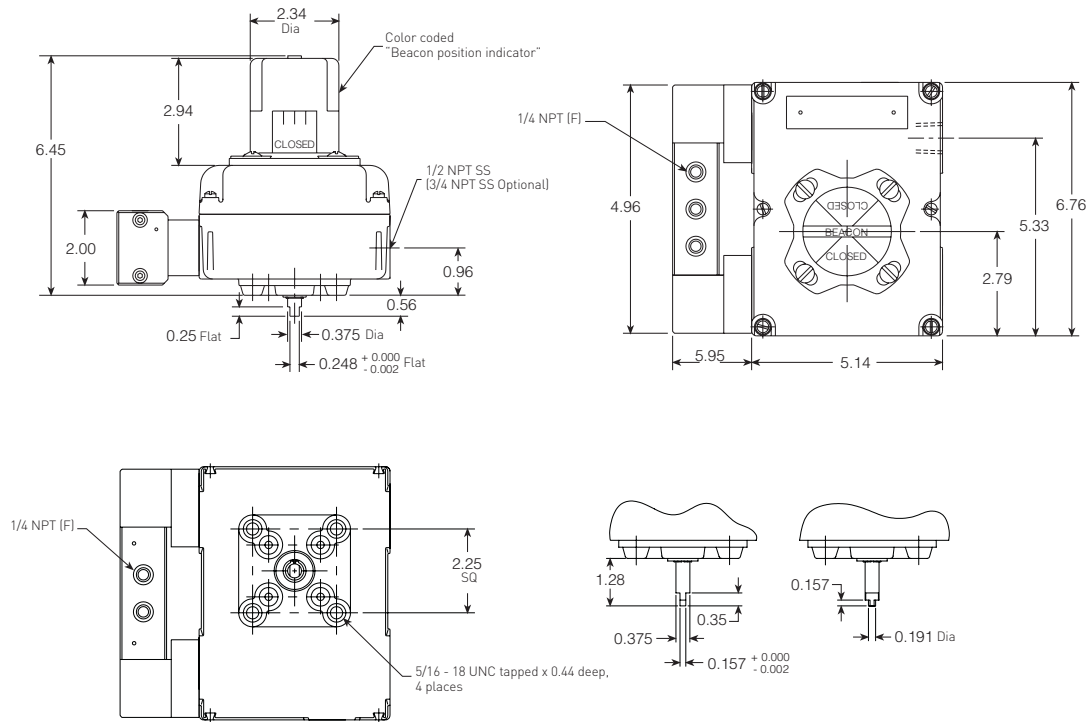

Dimensions in inches

### TECHNICAL SPECIFICATIONS

#### Materials of construction

Enclosure	Engineered polyamide resin
Shaft and hardware	Stainless steel
Beacon visual indicator	Co-polyester
Bushing	Nylon

#### Drive shaft

Westlock standard	Double-D with 1/4" A/F
NAMUR standard	NAMUR standard VDI/VDE 3845

### SOLENOID VALVES

The Falcon range of solenoid valves allows you to choose the material, voltage, number of ports, number of coils and  $C_v$  to best suit your application. See the Falcon data sheet for more information.

### NOTES

- Intellis control monitors are available with a choice of conduit entries. Please see the selection guide for standard entries
- Please consult your sales office for any other requirements

# INTELLIS NETWORK CONTROL MONITORS

## NON-INCENDIVE SELECTION GUIDE

<b>Network protocol</b>											
72	PROFIBUS-DP									75	Modbus
73	FOUNDATION fieldbus™									76	DeviceNet™
	(Standard intrinsically safe, class 1, all groups)									77	AS-interface® - Profile 3.0 (AS-i Profile 2.0 also available)
74	Modbus direct										
<b>Enclosure (Enclosure options available in 316 SS)</b>											
04	Aluminum enclosure										
44	Engineered resin enclosure										
45	Engineered resin enclosure (for dual coil)										
<b>Shaft output</b>											
S	Standard (Double-D with 1/4" Flats)										
N	NAMUR										
0	None										
<b>Beacon</b>											
BY	BM2-Y (Standard)							B3	BM3-3		
RG	BM2-RG							B5	BM3-5		
FE	BM2-Y-FE (French/English)							B7	BM3-7		
AB	BM2-B							B9	BM3-9		
AR	BM2-R							FC	Flat cover		
B1	BM3-1							JB	Junction box - flat cover, bushing plugged (use with '0' shaft output option)		
<b>Conduit</b>											
1A	One 1/2" NPT (F) with gland fitting										
1B	One 3/4" NPT (F)										
2A	Two 1/2" NPT (F) with gland fitting										
1M	One 1/2" NPT fitted with mini-connector										
1U	One 1/2" NPT fitted with micro-(Euro) connector										
2M	One 1/2" NPT fitted with mini-connector and one extra 1/2" NPT (F)										
2U	One 1/2" NPT fitted with micro-(Euro) conn. and one extra 1/2" NPT (F)										
<b>Position switches</b>											
2HEM	2 inputs / 2 outputs (only available for 76 or 77 Network protocols)										
2HES	4 inputs / 2 outputs										
<b>On/off junction enclosure</b>											
00	Not available										
<b>Coil voltage</b>											
0	None										
D	24 V DC (7.2 V DC for Fieldbus) – standard										
<b>Falcon V valve body</b>											
2V3	1.4 Cv, 3-way, brass							2V7	1.4 Cv, 4-way, brass		
3V3	1.4 Cv, 3-way, aluminum							3V7	1.4 Cv, 4-way, aluminum		
5V3	1.4 Cv, 3-way, 316 SS							5V7	1.4 Cv, 4-way, 316 SS		
3V4	4.3 Cv, 3-way, aluminum**							3V8	4.3 Cv, 4-way, aluminum		
2VY	1.4 Cv, dual coil, brass*							3VY	1.4 Cv, dual coil, aluminum*		
5VY	1.4 Cv, dual coil, 316 SS*							3VZ	4.3 Cv, dual coil, aluminum*		
<b>Valve options</b>											
0	None										
M	Momentary over-ride										
L	Locking over-ride										
R	Manual reset										
N	Manual reset with latch										
E	External pilot										
73	44	N	BY	1U	2HES	00	D	3V3	0	= Model number <b>7344NBY1U2HES00D3V30</b>	

\* Dual coil valve body options only available with enclosure '45'

\*\* 3V4 valves are 3V8 valves with ports 2 and 3 plugged at factory for 3-way functionality.

# INTELLIS NETWORK CONTROL MONITORS

## EXPLOSIONPROOF ALUMINUM ENCLOSURE (SINGLE COIL) DIMENSIONS

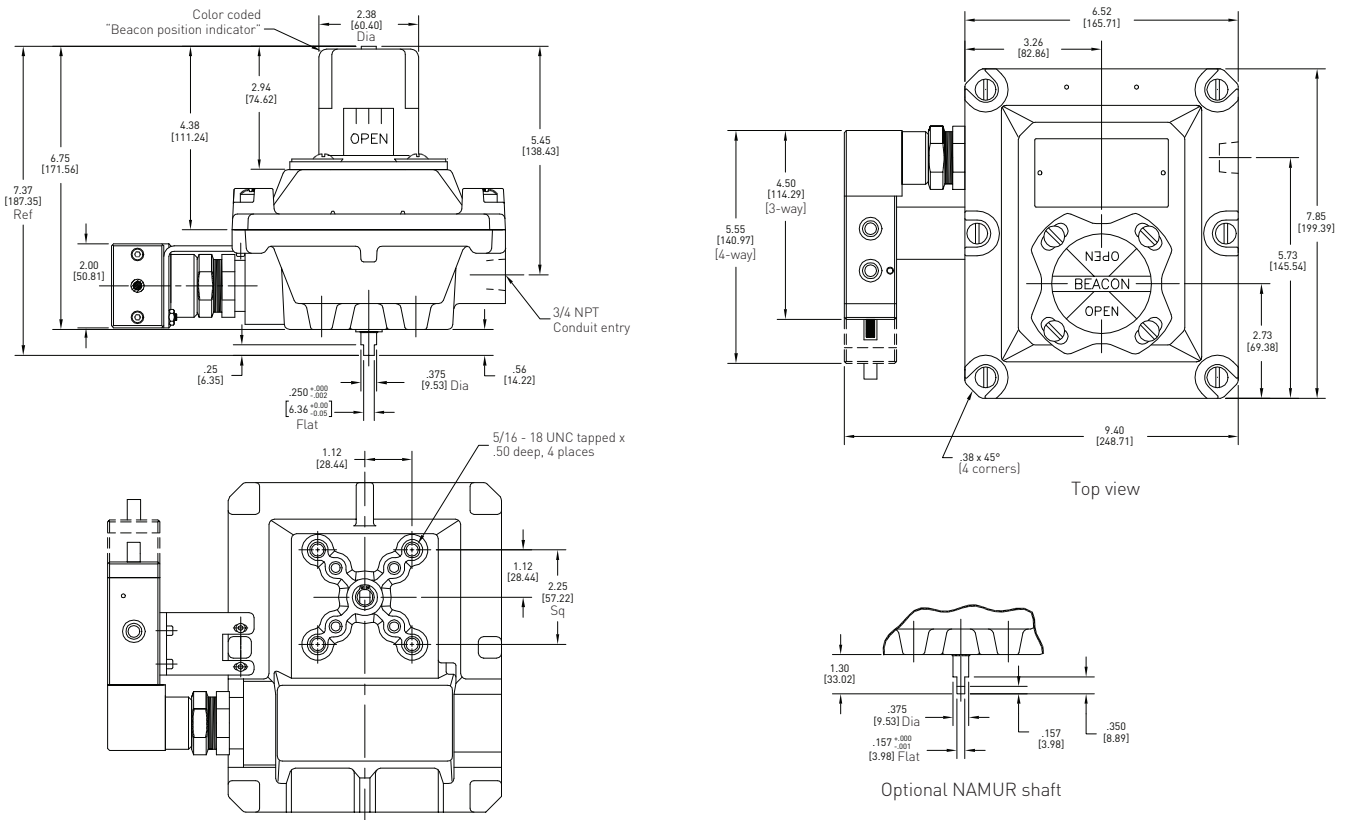

Dimensions in inches, metric dimension (mm) in parentheses

### TECHNICAL SPECIFICATIONS

#### Materials of construction

Enclosure	Aluminum with powder coat finish
Shaft and hardware	Stainless steel
Beacon visual indicator	Co-polyester
Bushing	Oil impregnated bronze

#### Drive shaft

Standard	Double-D with 1/4" A/F
Option	NAMUR standard VDI/VDE 3845

### SOLENOID VALVES

The Falcon range of solenoid valves allows you to choose the material, voltage, number of ports, number of coils and C<sub>v</sub> to best suit your application. See the Falcon data sheet for more information.

### NOTES

- Intellis control monitors are available with a choice of conduit entries. Please see the selection guide for standard entries
- Please consult your sales office for any other requirements

# INTELLIS NETWORK CONTROL MONITORS

## EXPLOSIONPROOF ALUMINUM ENCLOSURE (DUAL COIL) DIMENSIONS

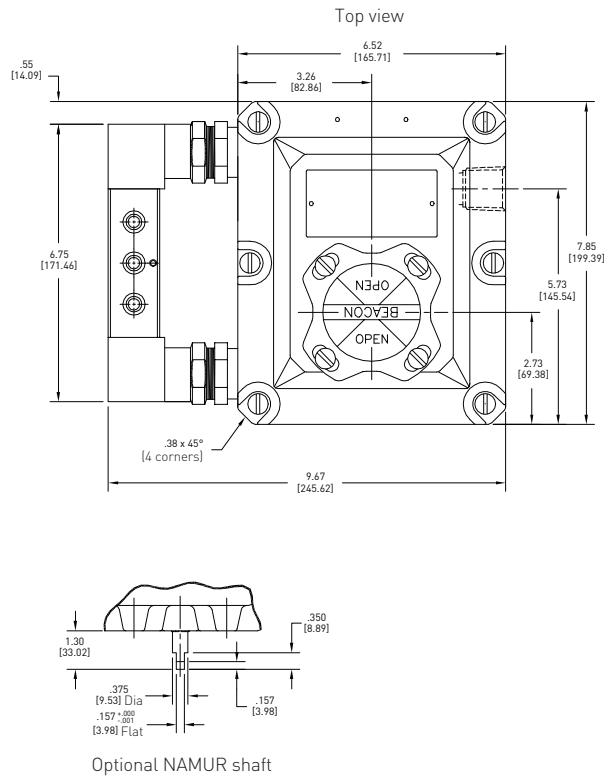
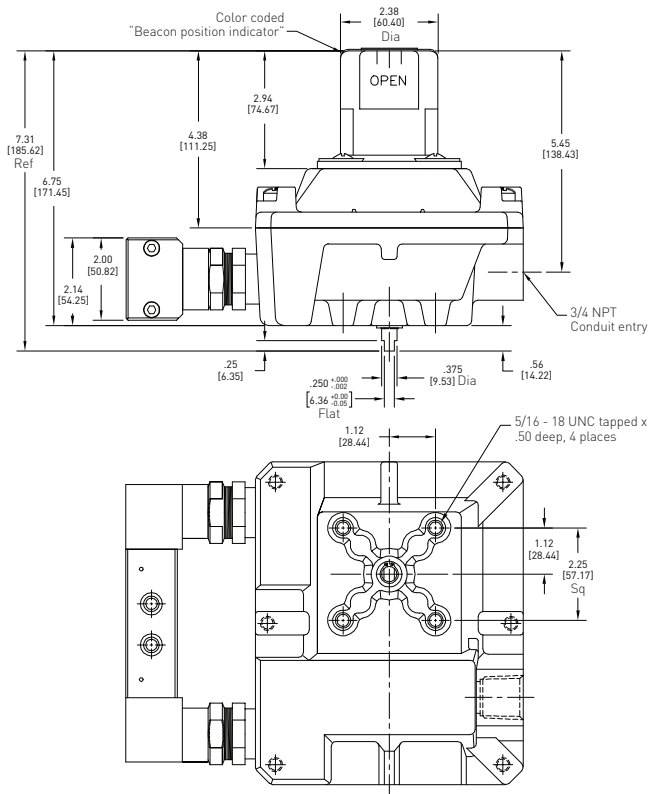

Dimensions in inches, metric dimension (mm) in parentheses

### TECHNICAL SPECIFICATIONS

#### Materials of construction

Enclosure	Aluminum with powder coat finish
Shaft and hardware	Stainless steel
Beacon visual indicator	Co-polyester
Bushing	Oil impregnated bronze
<b>Drive shaft</b>	
Standard	Double-D with 1/4" A/F
Option	NAMUR standard VDI/VDE 3845

### SOLENOID VALVES

The Falcon range of solenoid valves allows you to choose the material, voltage, number of ports, number of coils and C<sub>v</sub> to best suit your application. See the Falcon data sheet for more information.

### NOTES

- Intellis control monitors are available with a choice of conduit entries. Please see the selection guide for standard entries
- Please consult your sales office for any other requirements

# INTELLIS NETWORK CONTROL MONITORS

## EXPLOSIONPROOF SELECTION GUIDE

<b>Network protocol</b>	
72	PROFIBUS-DP
74	Modbus® Direct
75	Modbus®
76	DeviceNet™
77	AS-interface® - Profile 3.0 (AS-i Profile 2.0 also available)
<b>Enclosure</b>	
75	Aluminum enclosure (for dual coil)
79	Aluminum enclosure
89	Screw top aluminum enclosure (only available for 76 or 77 network protocol; only available for 2HEM position switches)
<b>Shaft output</b>	
S	Standard (Double-D with 1/4" Flats)
N	NAMUR
0	None
<b>Beacon</b>	
BY	BM2-Y (Standard)
RG	BM2-RG
FE	BM2-Y-FE (French/English)
AB	BM2-B
AR	BM2-R
B1	BM3-1
B3	BM3-3
B5	BM3-5
B7	BM3-7
B9	BM3-9
FC	Flat cover
JB	Junction box - flat cover, bushing plugged (use with '0' shaft output option)
<b>Conduit</b>	
1B	One 3/4" NPT (F)
2B	Two 3/4" NPT (F)
<b>Position switches</b>	
2HEM	2 inputs / 2 outputs (only available for 76 or 77 Network protocol)
2HES	4 inputs / 2 outputs (not available for enclosure option 89)
<b>On/off junction enclosure</b>	
00	Not available
01	On/off junction enclosure
<b>Coil voltage</b>	
0	None
X	24 V DC (XP coil)
<b>Falcon V valve body</b>	
2V3	1.4 Cv, 3-way, brass
3V3	1.4 Cv, 3-way, aluminum
5V3	1.4 Cv, 3-way, 316 SS
3V4	4.3 Cv, 3-way, aluminum**
2VY	1.4 Cv, dual coil, brass*
5VY	1.4 Cv, dual coil, 316 SS*
2V7	1.4 Cv, 4-way, brass
3V7	1.4 Cv, 4-way, aluminum
5V7	1.4 Cv, 4-way, 316 SS
3V8	4.3 Cv, 4-way, aluminum
3VY	1.4 Cv, dual coil, aluminum*
3VZ	4.3 Cv, dual coil, aluminum*
<b>Valve options</b>	
0	None
M	Momentary over-ride
L	Locking over-ride
R	Manual reset
N	Manual reset with latch
E	External pilot

77 75 N BY 1B 2HES 01 X 3V3 L = Model number **7775NBY1B2HES01X3V3L**

\* Dual Coil valve body options only available with enclosure '75'

\*\* 3V4 valves are 3V8 valves with ports 2 and 3 plugged at the factory for 3-way functionality.



www.westlockcontrols.com

Westlock. We reserve the right to change designs and specifications without notice.